

# SF82 Online

## Fast-Response Dew-Point Hygrometer

Easy to install and maintain, the SF82 Online Hygrometer measures and displays dew point and moisture content for use in a wide range of moisture applications. The SF82 Online display provides analog, digital and dual relay alarm outputs.



### Highlights

- Measurement range -60 to +60 °C dew point
- Accuracy  $\pm 2$  °C dew point
- 4 to 20 mA output
- Modbus RTU over RS485 output
- Dual configurable alarm outputs
- Sample block and cable included
- Traceable 9-point calibration certificate
- Ultra-fast response to moisture change

### Applications

- Membrane dryers
- Adsorption dryers
- Medical and surgical air
- Breathing air
- Additive manufacturing
- Glove boxes
- Plastic injection moulding



## SF82 Online

### Fast-Response Hygrometer

The SF82 Online has been developed as a fast-response, quick-to-install hygrometer system for the complete dew-point measurement range of -60 up to +60 °C dew point, which covers many moisture measurement applications.

This hygrometer incorporates the latest Process Sensing Technologies advanced thick film technology, providing stable, reliable and repeatable moisture measurements.

### Ease of Installation

The SF82 Online is supplied complete with all the parts required to install the sensor in a gas stream and start measuring quickly and easily.

- SF82 2-wire sensor
- Configurable display with 1/8 DIN mount format
- Stainless-steel sensor sample block with 1/8" NPT inlet and outlets
- Sensor cable – selectable length

The system is supplied with a 9-point calibration certificate from -60 to +20 °C dew point, traceable to national standards.

### Service Exchange/Recalibration Program

Michell offers 2 services for customers who want minimum downtime and sensor traceability, while maintaining the reliability of their online system:

- **Sensor Exchange** – Customers place an order for a guaranteed, reconditioned sensor, supplied with a 9-point traceable calibration. When this arrives, they exchange it for the installed sensor which is returned to Michell, resulting in zero process downtime.
- **Recalibration** – Customers return their installed sensor to Michell, where it is inspected, checked and recalibrated before being returned. This provides on-going sensor traceability for the process.

### Flexible Output Signals

The SF82 Online includes 3 digital and analog output signals, which can be reconfigured as required within the display menu system:

- 4–20 mA or 0–20 mA
- Modbus RTU over RS485
- 2 programmable relay alarms

### Safety and Integrity

The mechanical design of the sensor considers the health and safety quality requirements of the end user, offering an ultra-high process pressure barrier, along with meticulous levels of product traceability and quality.

- 450 barg pressure rating
- Optional gas wetted parts BS EN 10204 3.1 material certified
- 9-point calibration certificate

### Measurement Performance

The online system uses PST's market-leading thick film measurement technology coupled with the latest-generation, sophisticated microcontroller electronics to provide accurate and stable measurement across the transmitter's product life.

- Accuracy  $\pm 2^{\circ}\text{Cdp}$
- Fast response to moisture changes

### Flexibility of Ownership

The SF82 sensor used within the online system has a built-in diagnostic interface, which can be interrogated via the Michell Sensor Communications Kit.

Sensor information includes:

- Last calibration date
- Sensor health diagnostics

### Speed of Supply

The online system is manufactured within Michell's world-leading high-volume moisture transmitter manufacturing centre in the United Kingdom, which ensures reliability and repeatability of delivery and field supported by a network of Michell's global service centres.

- Manufacturing calibration system traceable to NPL and NIST
- ISO17025 UKAS accredited calibration available on request

### Customization

If your application requires a customized online system, we have specialized design and manufacturing capability to cover your requirements.

## Technical Specifications

Performance Specifications	
Measurement Range	-60 to +60°C dew point; -50 to +50°C dew point; -50 to +30°C dew point; non-standard dp ranges and ppm <sub>v</sub> ranges available on request
Accuracy	±2°C dew point*
Response Time	T95 to -60°C dew point in <3 minutes
Repeatability	0.5°C dew point
Sensor Calibration	Traceable 9-point calibration certificate
Electrical Specifications	
Online Output Signals	4–20 mA or 0–20 mA; Modbus RTU over RS485; dual programmable relay alarms
Online Output	Dew point
Maximum Analog Output Scaled Range	Dew point: -80 to +20°C
Online Supply Voltage	AC: 85 to 264V AC
Online Current Consumption	60 mA maximum
Electrical Safety	EN61010-1
Operating Specifications	
Operating Temperature	Sensor: -20 to +60°C; Monitor: 0 to 50°C
Compensated Temperature Range	Sensor: -20 to +50°C; Monitor: not applicable
Storage Temperature	Sensor: -40 to +60°C; Monitor: -10 to 60°C
Operating Pressure	10 MPa (100 barg) maximum
Sensor Flow Rate	1 to 5 Nl/min mounted in standard sampling block; 0 to 10 m/sec direct insertion
Mechanical Specifications	
Ingress Protection	<b>Sensor MiniDIN:</b> IP66 in accordance with standard BS EN 60529:1992+A2:2013; NEMA 4 protection in accordance with standard NEMA 250–2014 <b>Sensor M12:</b> IP65 <b>Monitor:</b> IP65 (NEMA 4X) front panel only
Sensor Housing Material	316 stainless steel
Dimensions	<b>Sensor MiniDIN:</b> L=133mm x ø45mm (with connector cable) <b>Sensor M12:</b> L=156mm x ø45mm (with connector cable) <b>Monitor:</b> 1/8 DIN Case, 96 x 48 x 85mm (w x h x d)
Filter (Sensor Protection)	Standard: HMWPE <10µm
Sensor Process Connection	5/8" - 18 UNF, 3/4" - 16 UNF, G1/2" BSP
KF40 Flange Accessories	Flange for 5/8" 18 UNF and 3/4" 16 UNF process connections
Sensor Weight	150g
Sensor Electrical Connections	MiniDIN 43650 form C, M12 5 pin (A coded)
Online Sensor Cable	0.8, 2, 5, 10 metre connector/cable available
Sensor Diagnostic Conditions (factory programmed)	Sensor fault: 23 mA Under-range dew point: 4 mA Over-range dew point: 20 mA

NOTES \* Over Compensated Temperature Range

# SF82 Online

## Product Dimensions

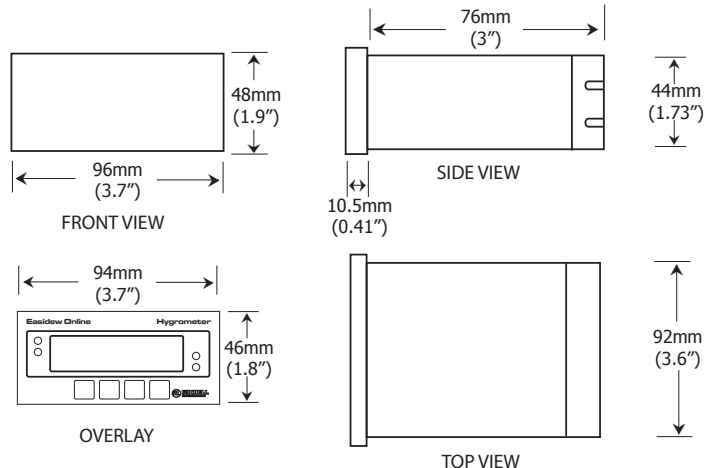

SF82 Online Monitor

### SF82 MiniDIN

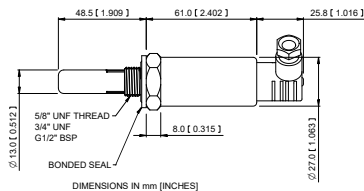

### SF82 M12

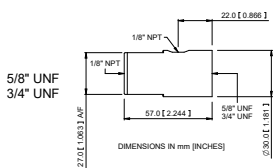
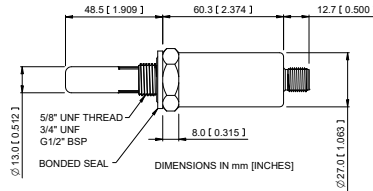

Optional Sample Block  
(see accessories and spare parts)

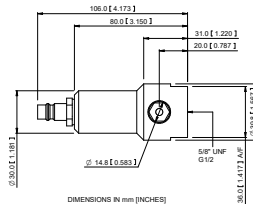

Optional Quick-Fit Sample Block  
(see accessories and spare parts)

## Related Process Products



**Easidew**  
Industrial Dew-Point Transmitter



**Optidew 501**  
Chilled Mirror Hygrometer



**Easidew PRO X.P.**  
Explosion Proof Moisture Transmitter



**Senz-TX**  
Oxygen Transmitter



**MDM50**  
Portable Hygrometer



**MDM300 I.S.**  
Dew-Point Hygrometer



**ES20**  
Compact Sampling System



**YellowBox Portable**  
Portable Oxygen Analyzer

Michell Instruments 48 Lancaster Way Business Park, Ely, Cambridgeshire, CB6 3NW  
Tel: +44 (0) 1353 658000, Fax: +44 (0) 1353 658199, Email: info@michell.com, Web: [www.michell.com/uk](http://www.michell.com/uk)

Michell Instruments adopts a continuous development programme which sometimes necessitates specification changes without notice.  
Issue no: SF82 Online\_99992\_V1\_UK\_0420